

Non Punch Through (NPT) IGBT

Description

The ZG25N120 is use advanced non punch through(NPT) technology ,the 1200V NPT IGBT offers superior conduction and switching performances.

General Features

- 1200V Breakdown Voltage
- Low saturation voltage: $V_{CE(sat),typ}=2.10V$
@ $I_C=25A$ and $T_C=25^{\circ}C$
- NPT Technology,Positive temperature coefficient

Application

- Solar Converters
- Welding Converters
- UPS

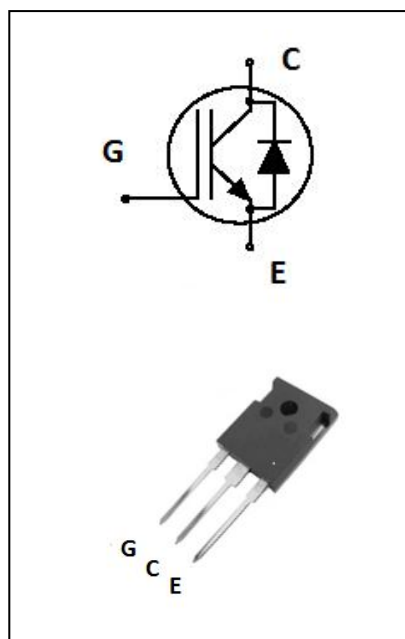

Electrical Characteristics @ $T_c=25^{\circ}C$ (unless otherwise specified)

a) Limited Parameters:

Symbol	Parameter	Value	Units
V_{CES}	Collector-Emitter Voltage	1200	V
V_{GES}	Gate-Emitter Voltage	+/-20	V
I_C	Collector Current	50	A
	Collector Current @ $T_c=100^{\circ}C$	25	A
I_{CM}	Pulsed Collector Current	60	A
I_F	Diode Continuous Forward Current @ $T_c=100^{\circ}C$	25	A
I_{FM}	Diode Maximum Forward Current	75	A
P_D	Total Dissipation at $T_a=25^{\circ}C$	430	W
	Total Dissipation at @ $T_c=100^{\circ}C$	300	
T_j	Operating Junction and Storage Temperature Range	-55 to +150	$^{\circ}C$
T_L	Max Temperature For Soldering	300	$^{\circ}C$



b) Electrical Parameters:

Symbol	Parameter	Test Conditions	Min	Typ	Max	Unit
V_{CES}	Collector-Emitter Voltage	$V_{GE}=0V, I_{CE}=250\mu A$	1200			V
$V_{CE(sat)}$	Collector-Emitter Saturation Voltage	$V_{GE}=15V, I_C=25A$		2.10	2.6	V
$V_{GE(th)}$	Gated Threshold Voltage	$V_{CE}=V_{GE}, I_C=1mA$	4.5	5.2	5.8	V
I_{CES}	Collector-Emitter Leakage Current	$V_{GE}=0V, V_{CE}=1200V$			25	μA
$I_{GES(F)}$	Gate to Emitter Forward Leakage	$V_{GE}=+20V,$			250	nA
$I_{GES(R)}$	Gate to Emitter Reverse Leakage	$V_{GE}=-20V,$			-250	nA
C_{ies}	Input Capacitance	$V_{GE}=0V,$ $V_{CE}=30V,$ $f=1.0MHz$		1050		pF
C_{oes}	Output Capacitance			160		pF
C_{res}	Reverse Transfer Capacitance			70		pF
Q_g	Total Gate Charge		$V_{CE}=400V$		126	
Q_{ge}	Gate to Emitter Charge	$I_C=25A$		20		nC
Q_{gc}	Gate to Collector Charge	$V_{GE}=15V$		66		nC

Symbol	Parameter	Test Conditions	Min	Typ	Max	Unit
$t_{d(on)}$	Turn-on Delay Time	$V_{CE}=600V, I_C=25A$ $V_{GE}=15V, R_G=68\Omega$		190		nS
t_r	Rise Time			76		nS
$t_{d(off)}$	Turn-off Delay Time			290		nS
t_f	Fall Time			395		nS

Symbol	Parameter	Test Conditions	Min	Typ	Max	Unit
I_F	Diode Continuous Forward Current	$TC=100^\circ C$	25			A
I_{FM}	Diode Maximum Forward Current	$TC=100^\circ C$	75			A
V_F	Diode Forward Voltage	$I_F=25A$		2.0	2.7	V
t_{rr}	Diode reverse recovery time	$I_F=1A, V_R=30V,$ $di/dt=200A/\mu s$		55		ns

Symbol	Parameter	Typ	MAX	Units
$R_{\theta JC}$	Thermal Resistance, Junction to case for IGBT	--	0.6	$^\circ C/W$
$R_{\theta JA}$	Thermal Resistance, Junction to Ambient	--	40	$^\circ C/W$

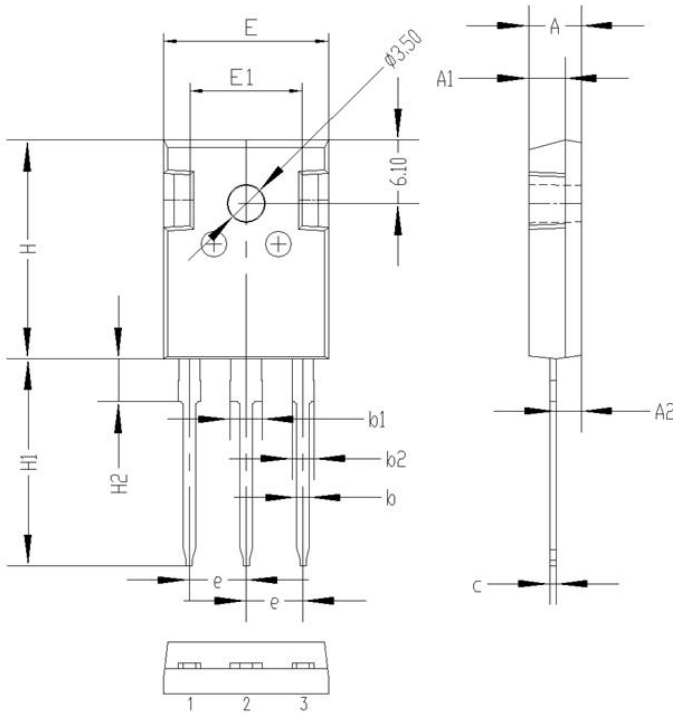
Package Information
TO-247 PACKAGE

Symbol	Dimensions(millimeters)	
	Min.	Max.
A	4.80	5.20
A1	3.30	3.70
A2	2.10	2.50
b	1.00	1.40
b1	2.90	3.30
b2	1.90	2.30
c	0.40	0.80
e	5.25	5.65
E	15.6	16.0
E1	10.6	11.00
H	20.8	21.2
H1	19.4	20.4
H2	3.90	4.30
G	5.90	6.30
ΦP	3.30	3.70

Notice

Thunder Microelectronics Incorporated Limited reserves the right to make changes without further notice to any products or specifications herein. When use the product, be sure to obtain the latest specification.

Thunder Microelectronics Incorporated Limited does not assume any liability arising out of the application or any product described herein. When using Thunder Microelectronics Incorporated Limited products in your equipment, you are requested to take adequate safety measures to prevent the equipment from causing a physical injury ,fire or other problem if any of the products become faulty.