



# 17N80

## 17A N-Channel Power MOSFET

### Features

New technology for high voltage device  
 Low on-resistance and low conduction losses  
 Small package  
 Ultra Low Gate Charge cause lower driving requirements  
 100% Avalanche Tested  
 ROHS compliant

### Mechanical Data

**Case :** TO-220AB

**Terminals :** Solder plated, solderable per MIL-STD-750, Method 2026

**Polarity :** As marked

**Mounting Position :** Any

### TO-220AB

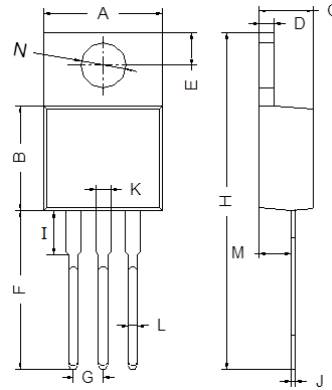

TO-220AB		
Dim	Min	Max
A	9.80	10.30
B	8.30	8.90
C	4.37	4.77
D	1.10	1.45
E	2.62	2.87
F	13.14	13.74
G	2.41	2.67
H	28.40	29.16
I	3.55	4.05
J	0.35	0.58
K	1.20	1.32
L	0.68	0.94
M	2.40	2.60
N	3.71	3.91

All Dimensions in mm

### Application

Power factor correction (PFC)  
 Switched mode power supplies(SMPS)  
 Uninterruptible Power Supply (UPS)

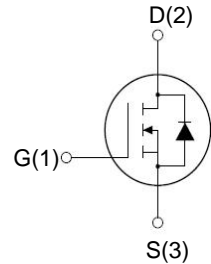
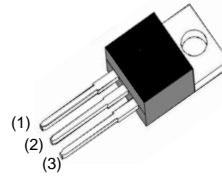

### Maximum Ratings And Electrical Characteristics

Ratings at 25°C ambient temperature unless otherwise specified. Single phase half-wave 60Hz, resistive or inductive load, for capacitive load current derate by 20%.

**Table 1. Absolute Maximum Ratings (T<sub>c</sub>=25°C)**

Parameter	Symbol	17N80	Unit
Drain-Source Voltage (V <sub>GS</sub> =0V)	V <sub>DS</sub>	800	V
Gate-Source Voltage (V <sub>DS</sub> =0V) AC (f>1 Hz)	V <sub>GS</sub>	±30	V
Continuous Drain Current at T <sub>c</sub> =25°C	I <sub>D(DC)</sub>	17	A
Continuous Drain Current at T <sub>c</sub> =100°C	I <sub>D(DC)</sub>	11	A
Pulsed drain current (Note 1)	I <sub>DM(pluse)</sub>	68	A
Maximum Power Dissipation(T <sub>c</sub> =25°C)	P <sub>D</sub>	265	W
Derate above 25°C		2.12	W/°C
Single pulse avalanche energy (Note 2)	E <sub>AS</sub>	324	mJ
Avalanche current (Note 1)	I <sub>AR</sub>	3	A
Repetitive Avalanche energy , t <sub>AR</sub> limited by T <sub>Jmax</sub> (Note 1)	E <sub>AR</sub>	1.8	mJ



®

Parameter	Symbol	17N80	Unit
Drain Source voltage slope, $V_{DS} \leq 480V$ ,	dv/dt	50	V/ns
Reverse diode dv/dt, $V_{DS} \leq 480V, I_{SD} < I_D$	dv/dt	15	V/ns
Operating Junction and Storage Temperature Range	$T_J, T_{STG}$	-55...+150	°C

\* limited by maximum junction temperature

**Table 2. Thermal Characteristic**

Parameter	Symbol	17N80	Unit
Thermal Resistance, Junction-to-Case (Maximum)	$R_{thJC}$	0.47	°C/W
Thermal Resistance, Junction-to-Ambient (Maximum)	$R_{thJA}$	62	°C/W

**Table 3. Electrical Characteristics (TA=25°C unless otherwise noted)**

Parameter	Symbol	Condition	Min	Typ	Max	Unit
<b>On/off states</b>						
Drain-Source Breakdown Voltage	$BV_{DSS}$	$V_{GS}=0V, I_D=250\mu A$	800			V
Zero Gate Voltage Drain Current( $T_C=25^\circ C$ )	$I_{DSS}$	$V_{DS}=800V, V_{GS}=0V$			1	$\mu A$
Zero Gate Voltage Drain Current( $T_C=125^\circ C$ )	$I_{DSS}$	$V_{DS}=800V, V_{GS}=0V$			100	$\mu A$
Gate-Body Leakage Current	$I_{GSS}$	$V_{GS}=\pm 20V, V_{DS}=0V$			$\pm 100$	nA
Gate Threshold Voltage	$V_{GS(th)}$	$V_{DS}=V_{GS}, I_D=250\mu A$	3	3.5	4	V
Drain-Source On-State Resistance	$R_{DS(ON)}$	$V_{GS}=10V, I_D=8.5A$		260	320	m $\Omega$
<b>Dynamic Characteristics</b>						
Input Capacitance	$C_{iss}$	$V_{DS}=50V, V_{GS}=0V,$ $F=1.0MHz$		2060		pF
Output Capacitance	$C_{oss}$			120		pF
Reverse Transfer Capacitance	$C_{rss}$			0.5		pF
Total Gate Charge	$Q_g$	$V_{DS}=480V, I_D=17A,$ $V_{GS}=10V$		36		nC
Gate-Source Charge	$Q_{gs}$			12.5		nC
Gate-Drain Charge	$Q_{gd}$			11		nC
<b>Switching times</b>						
Turn-on Delay Time	$t_{d(on)}$	$V_{DD}=480V, I_D=8.5A,$ $R_G=2.3\Omega, V_{GS}=10V$		14		nS
Turn-on Rise Time	$t_r$			12		nS
Turn-Off Delay Time	$t_{d(off)}$			65		nS
Turn-Off Fall Time	$t_f$			11		nS
<b>Source- Drain Diode Characteristics</b>						
Source-drain current(Body Diode)	$I_{SD}$	$T_C=25^\circ C$			17	A
Pulsed Source-drain current(Body Diode)	$I_{SDM}$				68	A
Forward On Voltage	$V_{SD}$	$T_J=25^\circ C, I_{SD}=17A, V_{GS}=0V$		0.9	1.2	V
Reverse Recovery Time	$t_{rr}$	$T_J=25^\circ C, I_F=8.5A, di/dt=100A/\mu s$		320		nS
Reverse Recovery Charge	$Q_{rr}$			3.1		$\mu C$
Peak Reverse Recovery Current	$I_{rrm}$			19		A

Notes 1.Repetitive Rating: Pulse width limited by maximum junction temperature

2.  $T_J=25^\circ C, V_{DD}=50V, V_G=10V, R_G=25\Omega$



## TYPICAL ELECTRICAL AND THERMAL CHARACTERISTICS (curves) 17N80

Figure1. Safe operating area

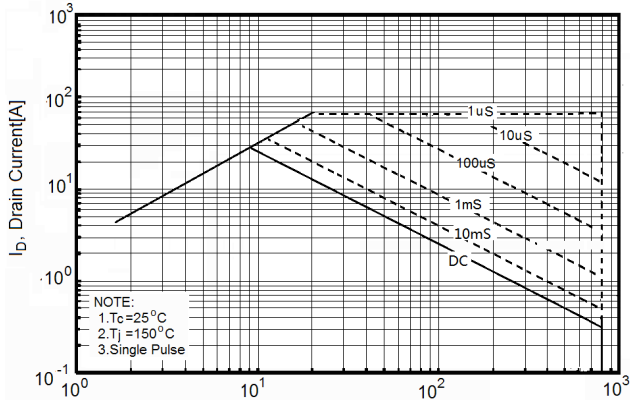

Figure2. Source-Drain Diode Forward Voltage

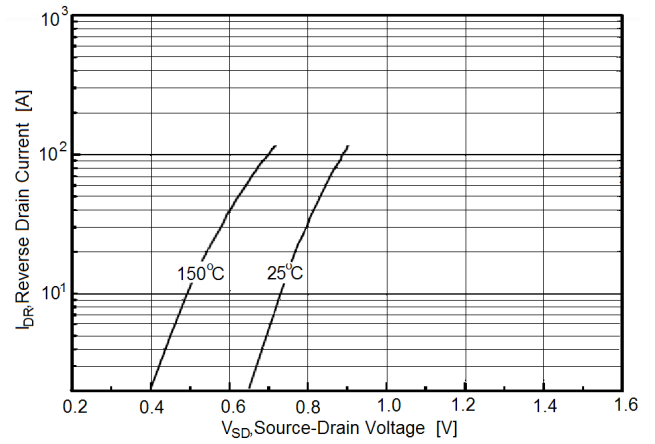

Figure3. Output characteristics

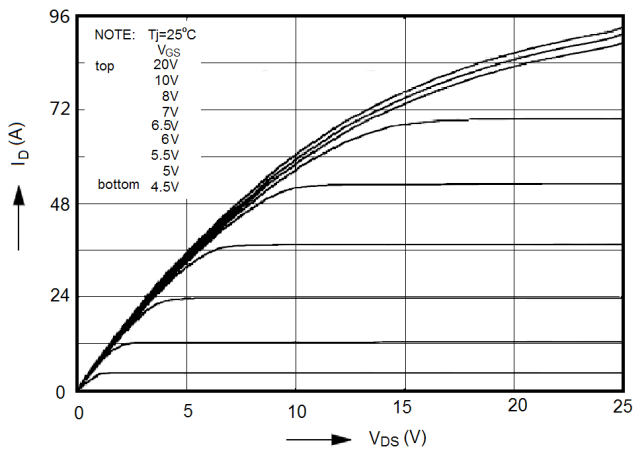

Figure4. Transfer characteristics

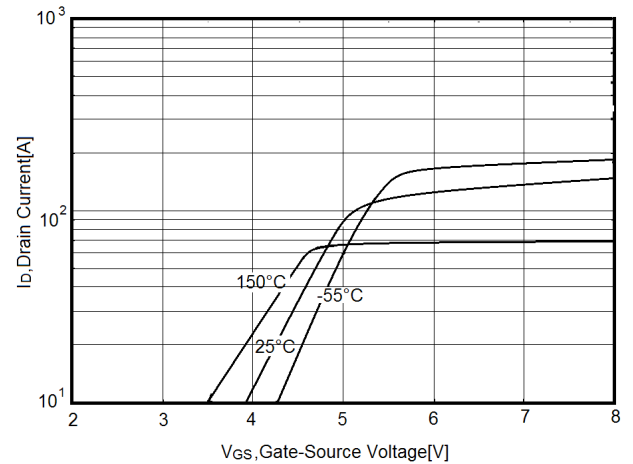
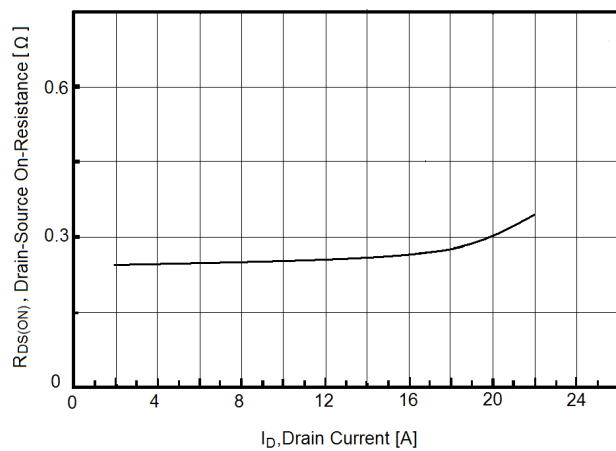

Figure5. Static drain-source on resistance





## TYPICAL ELECTRICAL AND THERMAL CHARACTERISTICS (curves) 17N80

Figure6.  $R_{DS(ON)}$  vs Junction Temperature

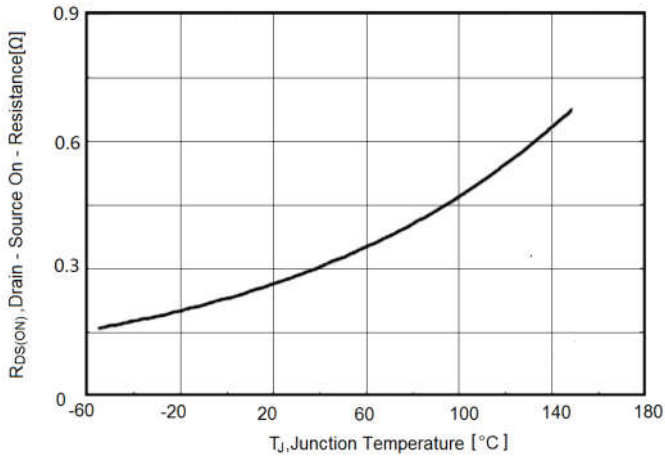

Figure7.  $BV_{DSS}$  vs Junction Temperature

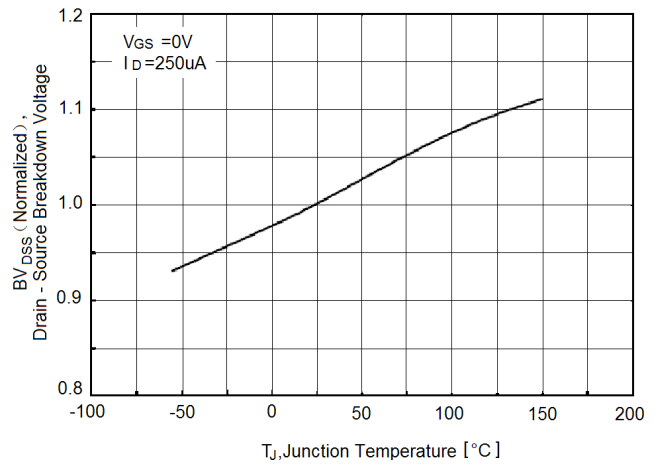

Figure8. Maximum  $I_D$  vs Junction Temperature

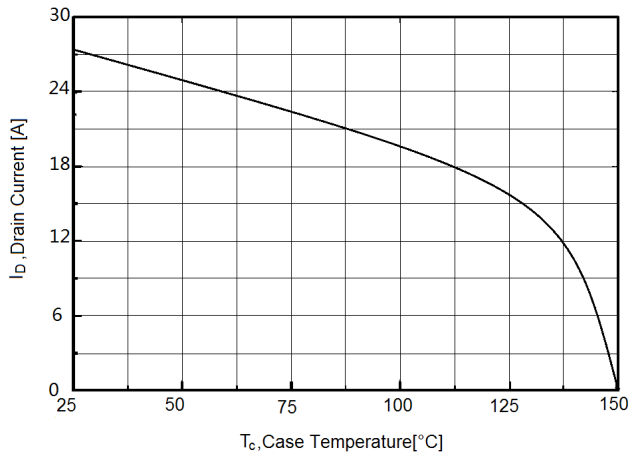

Figure9. Gate charge waveforms

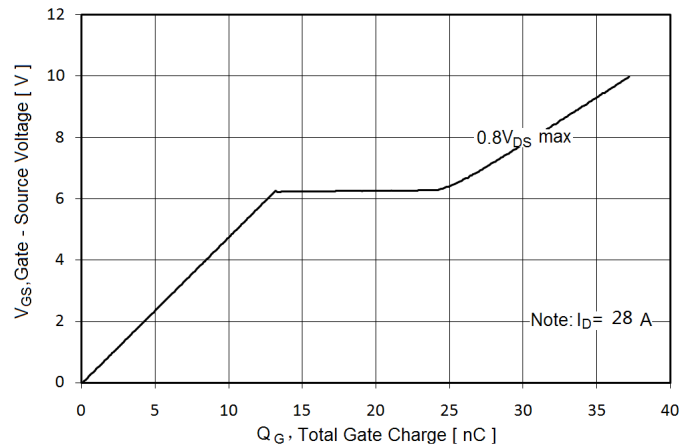

Figure10. Capacitance

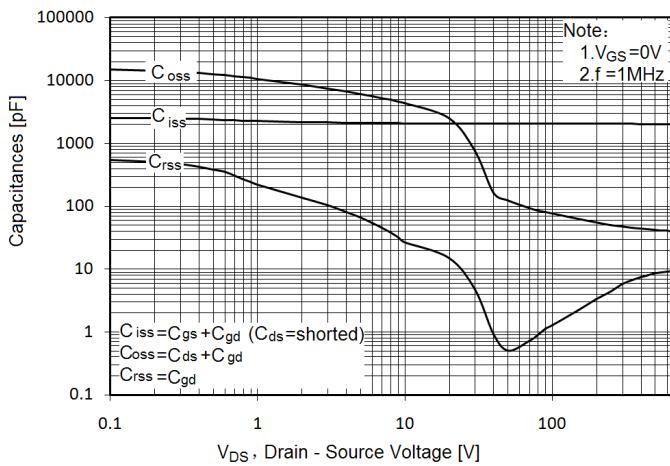

Figure11. Transient Thermal Impedance

